

Specifications

Sentry I Open-Air

Description

10 gpm, 24"x48" Tank, 1/2 hp 110v Pump

18 gpm, 30"x60" Tank, 1/2 hp 110v Pump

25 gpm, 39"x48" Tank, 3/4 hp 220v Pump

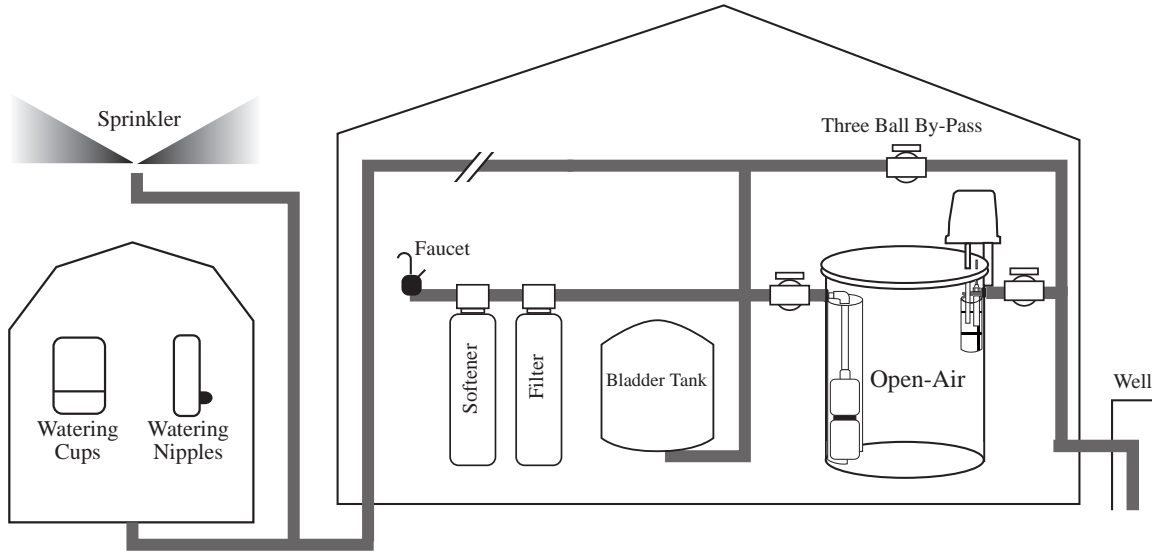

Sentry I	
Pellet Feed Rate (max)	8 pellets per minute
Pellet Feed Rate (min)	1 pellet per 21 minutes
Pellet Storage	5 or 10 lbs container

Specifications			
40/60 Pressure	10 gpm	18 gpm	25 gpm
Max Flow	14 gpm	22 gpm	28 gpm
Capacity	100 gal	180 gal	250 gal
Voltage	115 VAC	115 VAC	230 VAC
Operating Current	10 amp	10 amp	6.8 amp
Max Current	12 amp	12 amp	8 amp
Power	1/2 hp	1/2hp	3/4 hp
Freq	60 hz	60 hz	60 hz
Ship Weight	100 lb	115 lb	135 lb

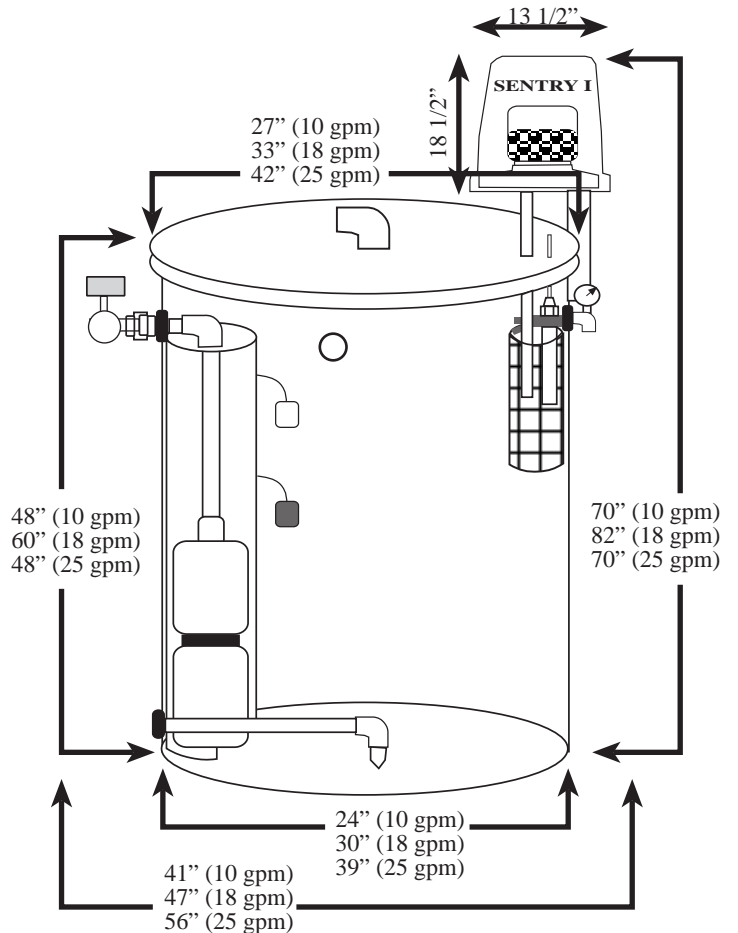

Better Water Industries, Inc

209 N Tyler St.
Tyler, MN 56178
(507) 247-5929
Fax (507) 247-3416
website: betterwaterind.com

Item no. SL
51206